

**14110
SERIES**

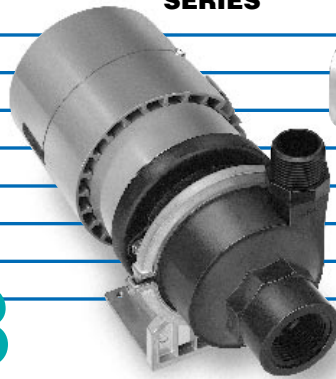

**14518
SERIES**



**14520
SERIES**

14110, 14518 & 14520 Series

Pump Specifications:

Flow Rates — Range to 27 gpm; maximum head 27.5 feet. Maximum system pressure is 75 psi.

Motors —
 a. 115V, 50/60 Hz; 230V, 50/60 Hz
 Vented, shaded pole, thermally protected
 b. 115V, 50/60 Hz; 230V, 50/60 Hz, TEFC/PSA, thermally protected

Fluid Temperature — To 203°F (95°C)

Materials in Contact with Solution:

Body — Ryton®
Impeller — Ryton® with Epoxy adhesive

Adapter — Ryton®
Pump Shaft — Ceramic
Impeller Bearings — Resin Impregnated Carbon
Front Thrust Bearings — Glass-Filled Teflon®
Rear Thrust Bearings — Ceramic
O-Rings (Elastomers) — a. EPT/EPDM
 b. Viton®/Fluoroelastomer

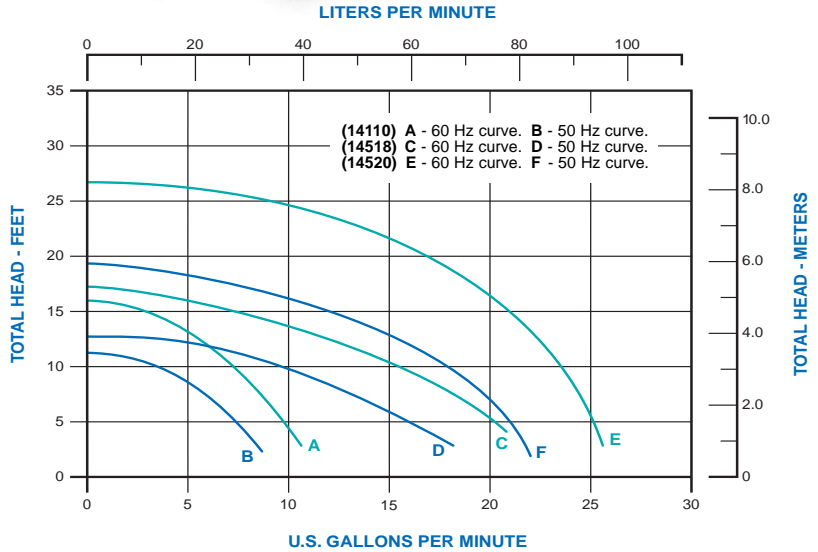

MODEL SPECIFICATIONS

| Model Number | O-Rings (Elastomers) | Motor Specifications | | | | | Overall Pump Dimen. - In. (mm) | | | | Typical Curve | | Approx. Wt. |
|--------------|------------------------|----------------------|-------|---------|------|--------|--|---|--|--|---------------|-------|-------------|
| | | Volts | Hz | Amps | Type | Shell | Length | Width | Height | | 50 Hz | 60 Hz | |
| | | | | | | | | | MPT | MHB | | | |
| 14110-050 | EPT/EPDM | 115 | 50/60 | .5/.5 | SP | VENTED | 8 ¹ / ₁₆ (204.7) | 5 (127.0) | 4 ³ / ₄ (120.7) | 4 ⁷ / ₈ (123.8) | B | A | 6.25 lbs. |
| 14110-051 | Viton®/Fluoroelastomer | | | | | | | | | | | | |
| 14110-052 | EPT/EPDM | 230 | 50/60 | .25/.25 | SP | VENTED | 8 ¹ / ₁₆ (204.7) | 5 (127.0) | 4 ³ / ₄ (120.7) | 4 ⁷ / ₈ (123.8) | B | A | 6.25 lbs. |
| 14110-053 | Viton®/Fluoroelastomer | | | | | | | | | | | | |
| 14518-050 | EPT/EPDM | 115 | 50/60 | 2.8/2.4 | SP | VENTED | 9 ⁹ / ₁₆ (244.6) | 5 ⁷ / ₁₆ (138.2) | 5 ¹ / ₈ (130.3) | 5 ¹ / ₄ (133.4) | D | C | 6.75 lbs. |
| 14518-051 | Viton®/Fluoroelastomer | | | | | | | | | | | | |
| 14518-052 | EPT/EPDM | 230 | 50/60 | 1.4/1.2 | SP | VENTED | 9 ⁹ / ₁₆ (244.6) | 5 ⁷ / ₁₆ (138.2) | 5 ¹ / ₈ (130.3) | 5 ¹ / ₄ (133.4) | D | C | 6.75 lbs. |
| 14518-053 | Viton®/Fluoroelastomer | | | | | | | | | | | | |
| 14520-050 | EPT/EPDM | 115 | 50/60 | 2.1/2.0 | PSC | TEFC | 10 ¹ / ₁₆ (255.5) | 5 ⁷ / ₁₆ (138.2) | 5 ¹ / ₈ (130.3) | 5 ¹ / ₄ (133.4) | F | E | 8.0 lbs. |
| 14520-051 | Viton®/Fluoroelastomer | | | | | | | | | | | | |
| 14520-052 | EPT/EPDM | 230 | 50/60 | 1.1/1.0 | PSC | TEFC | 10 ¹ / ₁₆ (255.5) | 5 ⁷ / ₁₆ (138.2) | 5 ¹ / ₈ (130.3) | 5 ¹ / ₄ (133.4) | F | E | 8.0 lbs. |
| 14520-053 | Viton®/Fluoroelastomer | | | | | | | | | | | | |

MAGNETIC DRIVE PUMPS - TYPICAL DIMENSIONS

14110 Series Model

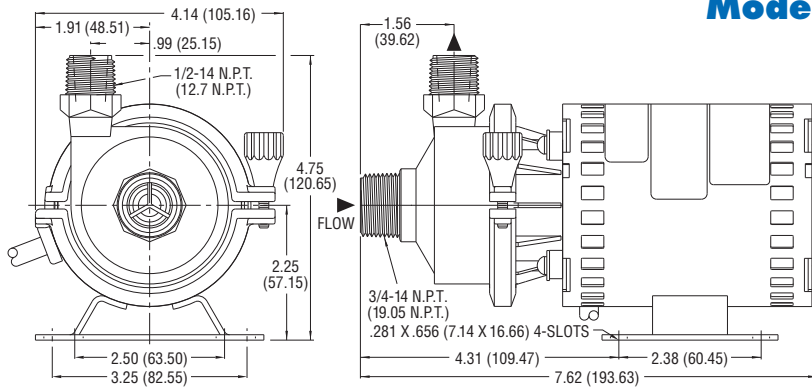

OEM
Options

O-Rings (Elastomers)

- a. Nitrile
- b. Neoprene
- c. Silicone
- d. Hypalon®
- e. Kel-F®
- f. Fluorosilicone (14110 & 14518/20 Series only)

Motors

- 115V, 50/60 Hz;
- 230V, 50/60 Hz
- Explosion-proof (14520 Series only)

14518 Series Model

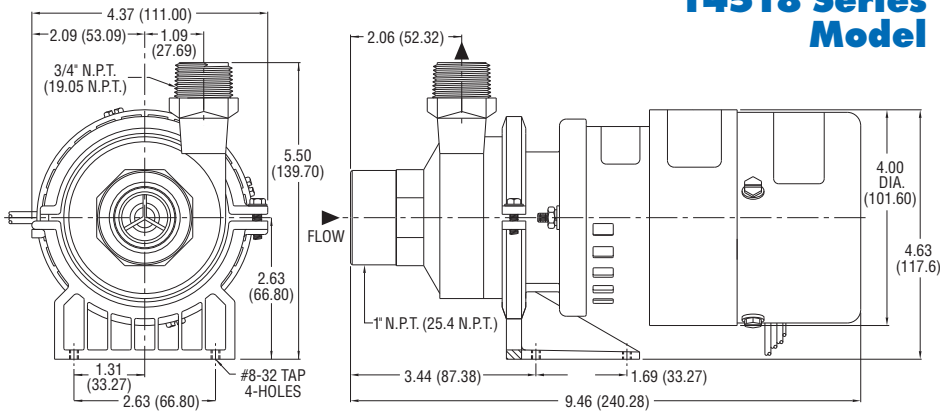

14520 Series Model

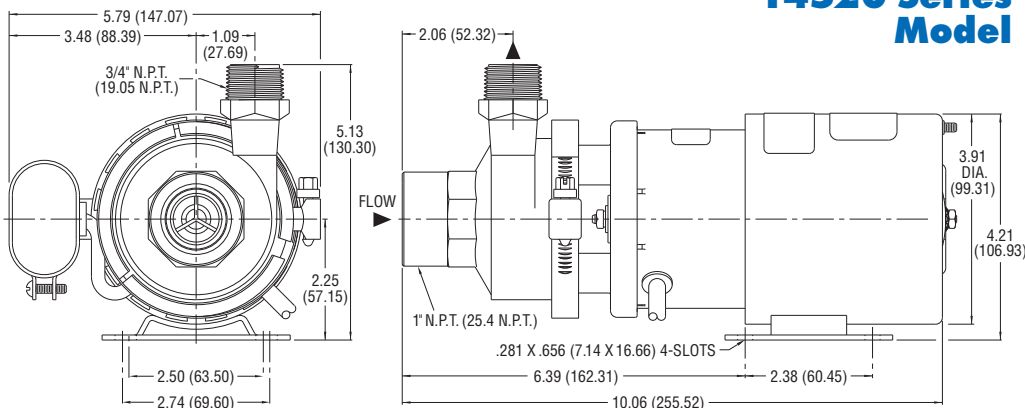

Dimensions in Inches
(Dimensions in Millimeters)