

Heavy-Duty Pumps

The heavy-duty models are specially designed for use in dusty environments or for those applications requiring extremely long life. The pump is supplied with a totally enclosed gearmotor with an expected life of over 10,000 hours. The standard crank mechanism is used on heavy-duty pumps. The heavy-duty pump is recommended for 24 hour/day continuous duty applications.



1½" HEAVY-DUTY MODEL

MODEL SPECIFICATIONS

Single Model Number		Bellows Diameter Inches	Discharge Strokes per minute (Motor RPM)		Maximum Flow ml per minute		Gallons (Liters) per hour		Max. Pressure PSI (kg/cm ²)	Electrical Amps* 115V 60 Hz	Approx. Wt. lbs.
115V/60 Hz	240V/60 Hz 220V/50 Hz		50 Hz	60 Hz	50 Hz	60 Hz	50 Hz	60 Hz			
15955-001	15955-002	1½	83	100	872	1,050	13.8 (52.3)	16.6 (63)	20 (1.5)	.6	6
15956-001	15956-002	2½	42	50	2,310	2,750	36.6 (138.6)	43.6 (165)	5 (.37)	.6	6

*Amp values for 240V will be approximately 50% of 115V values shown above.

HEAVY-DUTY BELLOWS - TYPICAL DIMENSIONS

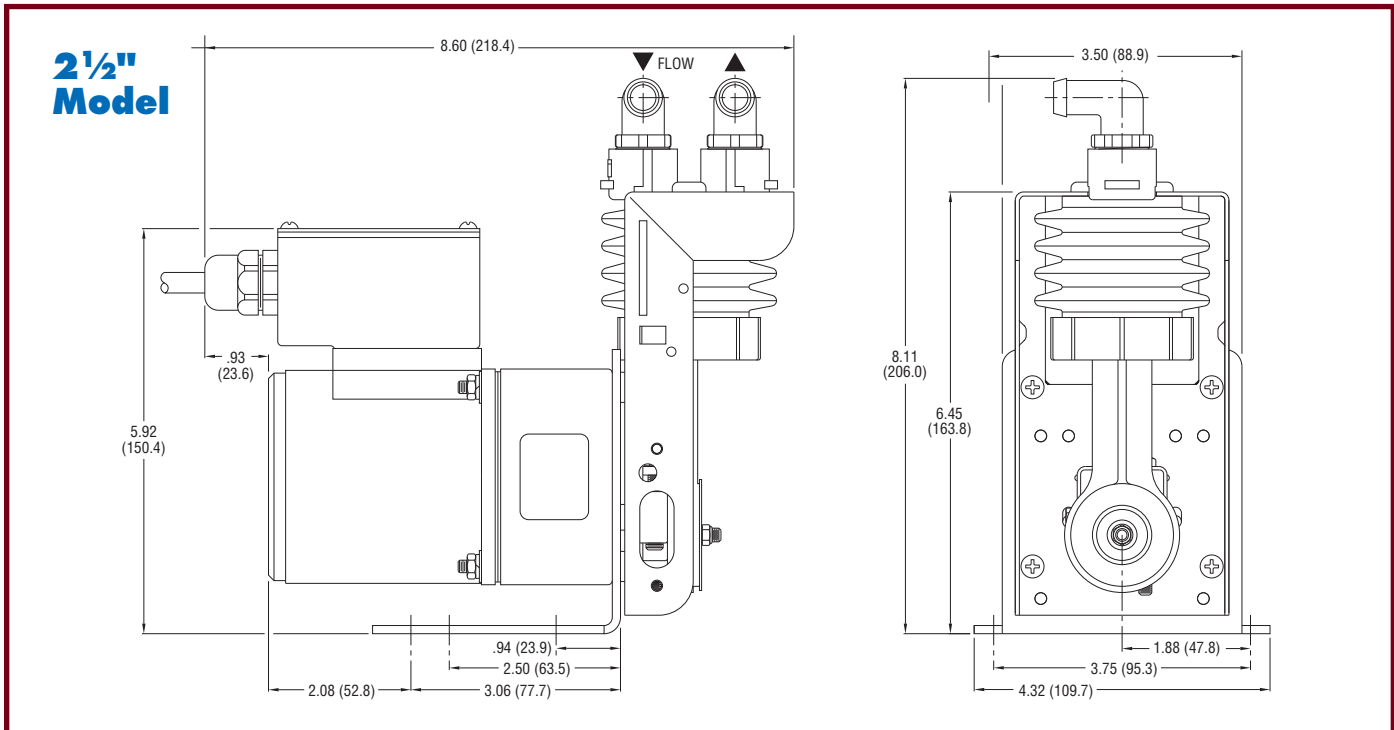
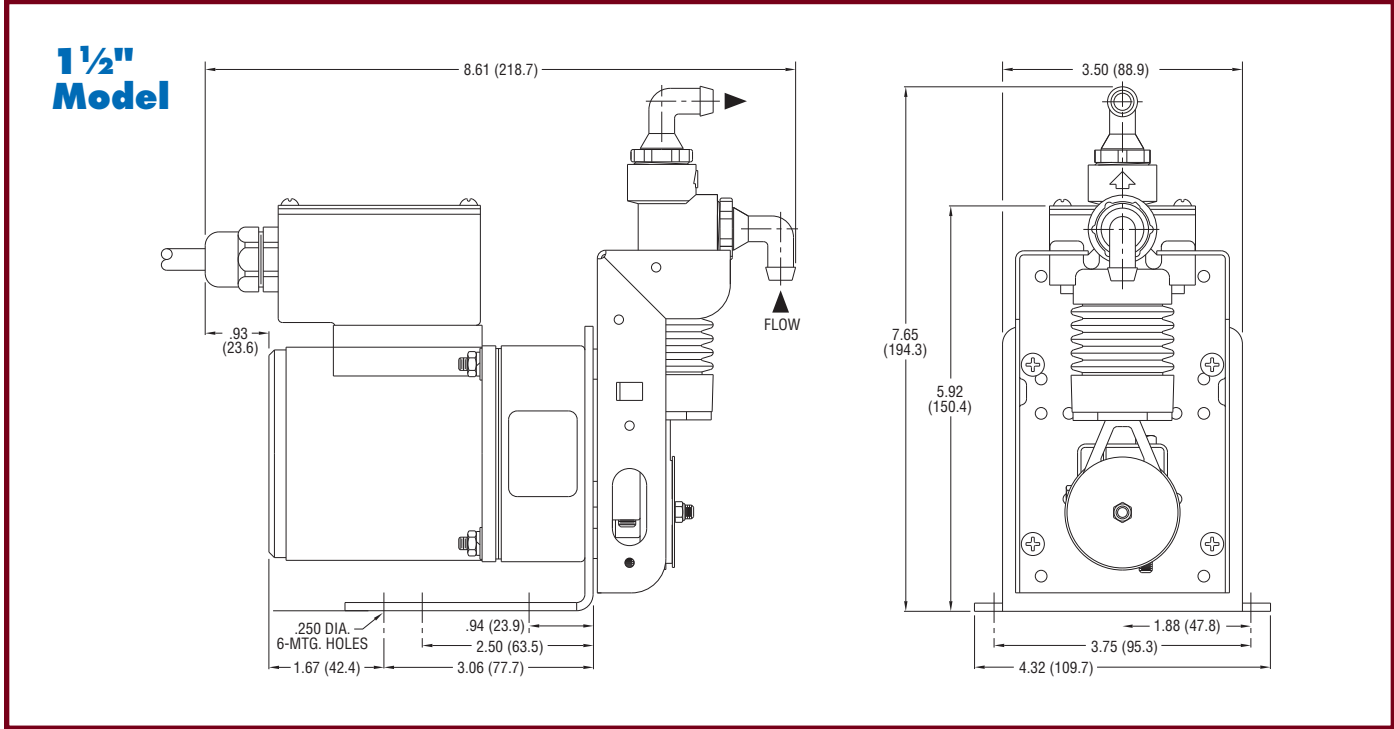

Dimensions in Inches (Dimensions in Millimeters)

Order Notes: When ordering a heavy-duty model, add one "X" code for valve and O-ring material selection and one "T" code for connector selection from the Bellows Pump Selection Guide.

Example: 15955-001 (1½" bellows model) with Hypalon® poppet valves and O-rings and elbow connectors for ½" I.D. tubing would be ordered as 15955-001 X-115 T-009.