



15700 SERIES

DIVISION OF THE GORMAN-RUPP COMPANY

Phone (419) 886-3001 / Telex: 4973725 / Fax (419) 886-2338

MAGNETIC DRIVE PUMPS

SERVICE DATA SHEET

with dry run capabilities

Model covered in this service data sheet has "dry run" capabilities without apparent detrimental effects. Consult the factory about your specific "dry run" requirements.

TROUBLESHOOTING GUIDE

The troubleshooting guide is a suggestion or aid in helping solve problems that might arise.

NOTE: NEVER WORK ON PUMP WITHOUT MAKING CERTAIN POWER IS OFF

UNIT WILL NOT PUMP:

1. No liquid in pump (requires flooded suction).
2. Closed valves or blocked lines.
3. Air lock in suction or discharge lines.

LOW FLOW:

1. Air leak in suction line.
2. Closed valves or blocked lines.
3. Dirty filter systems.
4. Reverse rotation (on 3-phase or dual voltage, reversible motors).
5. Low voltage.

MOTOR DOES NOT TURN:

1. No power to motor. Check that all power switches are on. Be sure fuse or circuit breaker is properly set. Timers or controls properly set. Check motor wiring at terminals or plug.

MOTOR RUNS HOT:

These motors will run "hot" to the touch. However, this is normal. Thermal overload protector will function to turn them off if there is an overload or high temperature problem. Excessive heat can be caused by:

1. Low voltage or incorrect voltage.
2. Installed in direct sun.
3. Poor ventilation.

MOTOR THERMAL PROTECTOR OPENS ELECTRIC CIRCUIT:

1. Motor is improperly connected.
2. Low voltage due to under-sized wire or low incoming voltage.
3. Incorrect voltage.
4. Overload due to binding in pump or bad motor bearings.

NOISY OPERATION OF MOTOR:

1. Worn bearings.
2. Damaged cooling fan.

NOISY OPERATION OF PUMP:

1. Air leak in suction line. Bubbles in liquid returning to pump inlet.
2. Restricted suction line due to blockage or under-size pipe.
3. Cavitation. (See 1. & 2. above).
4. Foreign matter in pump impeller.
5. Dry running pump bearing (with no liquid in pump). Intermittent noise levels can be expected under this condition.

LEAKS:

1. Loose hose clamps.
2. Leaking plastic thread adapters. (Use a thread sealant—do not overtighten.)
3. A compatible thread sealer should be used when installing fittings or adapters to the threaded pump body connections. A maximum assembly torque of 10 ft.-lbs. is recommended for the pump inlet and 5 ft.-lbs. for the pump outlet. (These torque values do not pertain when using Teflon-type tape. Due to the high degree of lubricity, the parts may be damaged before a reliable torque reading is attained—do not overtighten.)
4. Leaking O-ring gasket. (Tighten pump body mounting screws to 20 in.-lbs.)
5. Damaged or broken pump parts.

WARRANTY

Gorman-Rupp Industries warrants that its products are free from defects in title, material and workmanship. Warranty expires 15 months from date of manufacture. NO OTHER WARRANTY, WHETHER EXPRESS OR IMPLIED, INCLUDING ANY WARRANTY OF MERCHANTABILITY OR FITNESS FOR A PARTICULAR PURPOSE, SHALL EXIST IN CONNECTION WITH ANY PRODUCT SOLD BY GORMAN-RUPP INDUSTRIES, AND ALL SUCH WARRANTIES ARE HEREBY EXPRESSLY EXCLUDED.

15700 SERIES MAGNETIC DRIVE PUMPS

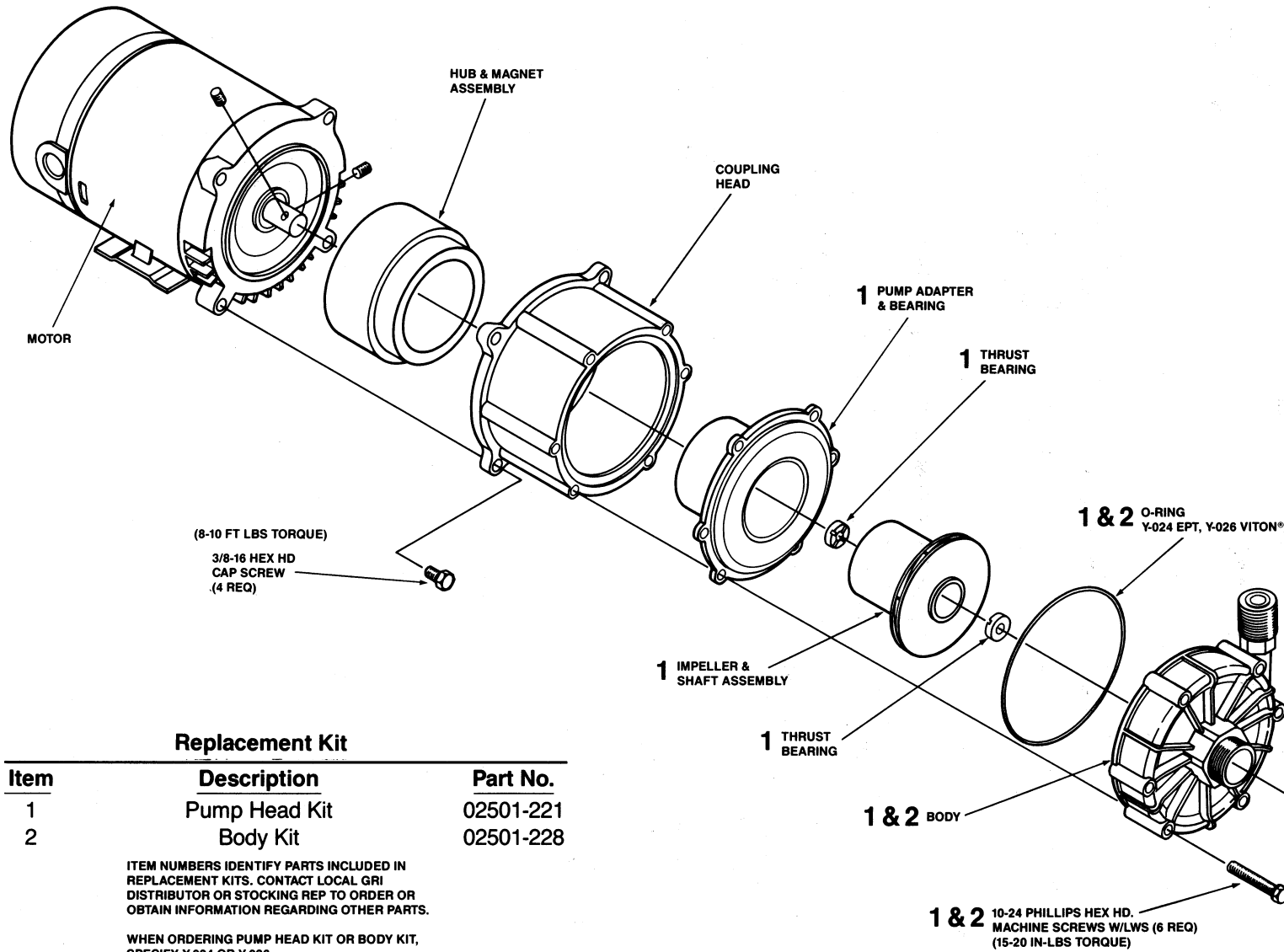

Replacement Kit

Item	Description	Part No.
1	Pump Head Kit	02501-221
2	Body Kit	02501-228

ITEM NUMBERS IDENTIFY PARTS INCLUDED IN REPLACEMENT KITS. CONTACT LOCAL GRI DISTRIBUTOR OR STOCKING REP TO ORDER OR OBTAIN INFORMATION REGARDING OTHER PARTS.

WHEN ORDERING PUMP HEAD KIT OR BODY KIT, SPECIFY Y-024 OR Y-026